

S.C. Kubitech S.R.L.
 700268 Iași, Bd. Socola 57, bl. A1, RO 8508803, J22/874/1996
 T/F: 0232 257.555, contact@kubitech.ro, www.kubitech.ro
 RO39 BPOS 2400 2831 438R OL01 - Bancpost Iași

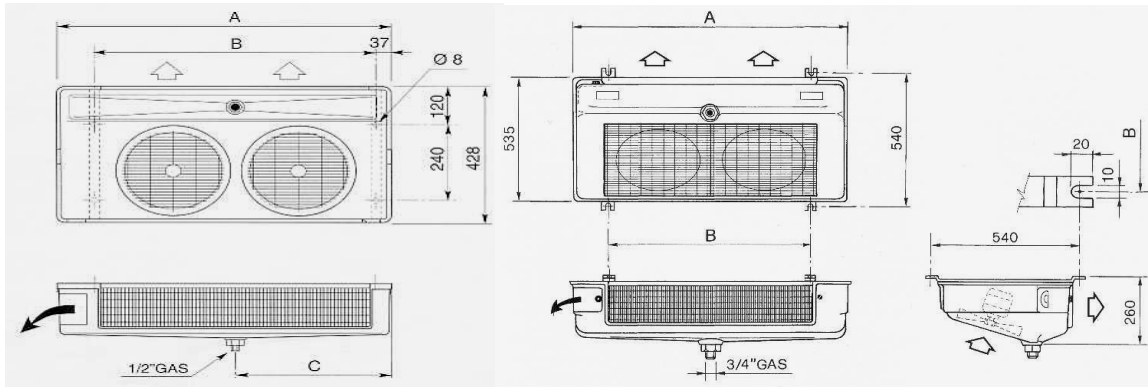

Kubitech
 tehnică de frig

Evaporatoare LU-VE



Evaporator SHS12	780W/dT=10K, 440 mc/h
Evaporator SHS18	1430W/dT=10K, 850 mc/h
Evaporator SHS26	2050W/dT=10K, 980 mc/h
Evaporator SHS32	2290W/dT=10K, 1250 mc/h

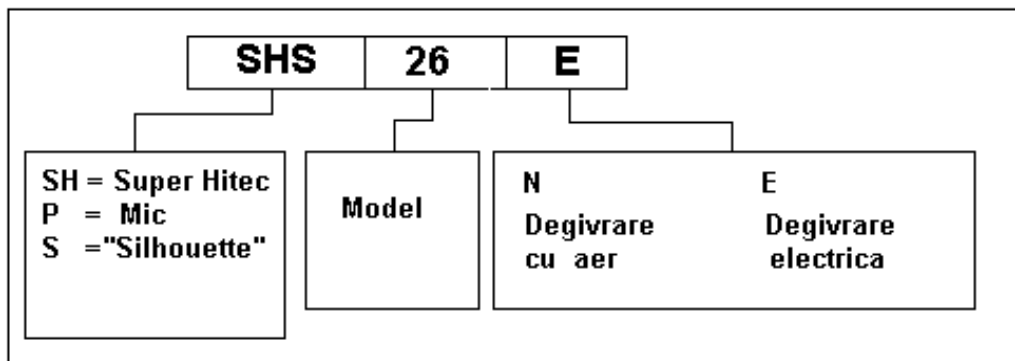

Evaporator SHA14E80	1100W/dT=10K, 750 mc/h
Evaporator SHA17E80	1400W/dT=10K, 850 mc/h
Evaporator SHA21E50	1450W/dT=10K, 700 mc/h
Evaporator SHA27E50	1850W/dT=10K, 800 mc/h
Evaporator SHA28E80	2300W/dT=10K, 1500 mc/h
Evaporator SHA30E32	1750W/dT=10K, 600 mc/h
Evaporator SHA35E80	2800W/dT=10K, 1700 mc/h
Evaporator SHA40E32	2200W/dT=10K, 700 mc/h
Evaporator SHA41E50	3000W/dT=10K, 1400 mc/h
Evaporator SHA52E80	4350W/dT=10K, 2550 mc/h
Evaporator SHA53E50	3700W/dT=10K, 1600 mc/h

Evaporator SHA60E32	3600W/dT=10K, 1200 mc/h
Evaporator SHA70E80	5900W/dT=10K, 3400 mc/h
Evaporator SHA79E50	5750W/dT=10K, 2400 mc/h
Evaporator SHA80E32	4400W/dT=10K, 1400 mc/h
Evaporator SHA106E50	7650W/dT=10K, 3200 mc/h
Evaporator SHA120E32	6750W/dT=10K, 2100 mc/h
Evaporator SHA160E32	8900W/dT=10K, 2800 mc/h

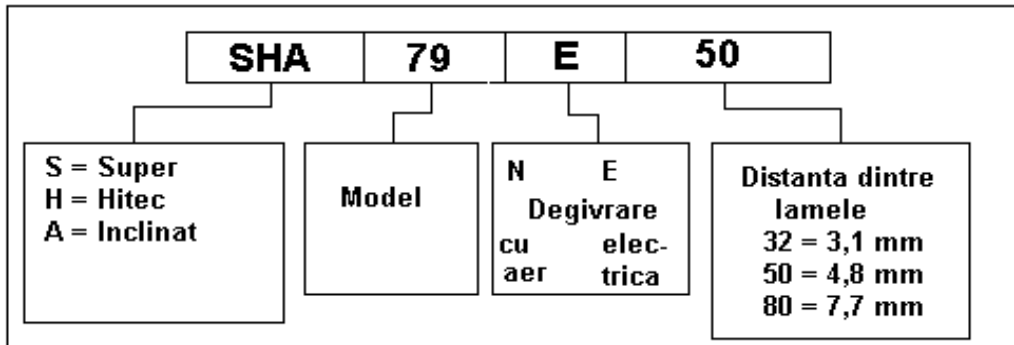

Evaporator S2HC16E80	1400W/dT=10K, 1050 mc/h
Evaporator S2HC19E65	1600W/dT=10K, 1000 mc/h
Evaporator S2HC23E80	1800W/dT=10K, 1050 mc/h
Evaporator S2HC25E50	1800W/dT=10K, 950 mc/h
Evaporator S2HC28E65	2050W/dT=10K, 1000 mc/h
Evaporator S2HC31E80	2900W/dT=10K, 2100 mc/h
Evaporator S2HC36E50	2350W/dT=10K, 950 mc/h
Evaporator S2HC38E65	3300W/dT=10K, 2000 mc/h
Evaporator S2HC46E80	3600W/dT=10K, 2100 mc/h
Evaporator S2HC49E50	3800W/dT=10K, 1900 mc/h
Evaporator S2HC55E65	4150W/dT=10K, 2000 mc/h
Evaporator S2HC70E80	5550W/dT=10K, 3150 mc/h
Evaporator S2HC71E50	4750W/dT=10K, 1900 mc/h
Evaporator S2HC85E65	6300W/dT=10K, 3000 mc/h
Evaporator S2HC92E80	7400W/dT=10K, 4200 mc/h
Evaporator S2HC107E50	7200W/dT=10K, 2850 mc/h
Evaporator S2HC110E65	8300W/dT=10K, 4000 mc/h
Evaporator S2HC142E50	9400W/dT=10K, 3800 mc/h

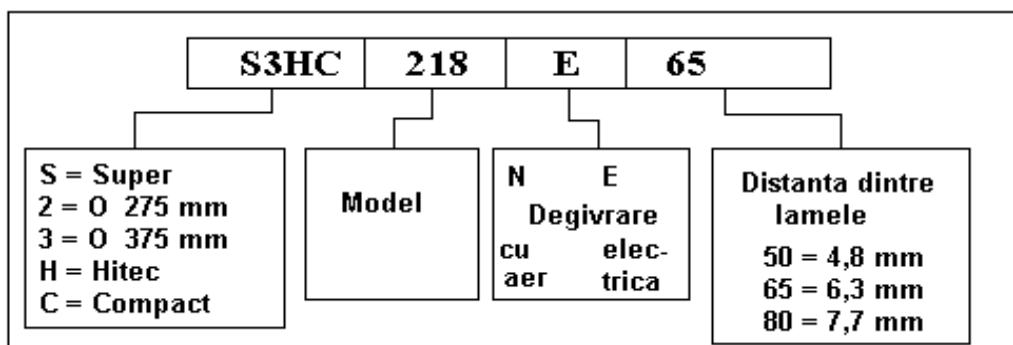

Evaporator S3HC47E80	3900W/dT=10K, 2700 mc/h
Evaporator S3HC59E65	4500W/dT=10K, 2650 mc/h

Evaporator S3HC69E80	5200W/dT=10K, 2600 mc/h
Evaporator S3HC73E50	5350W/dT=10K, 2600 mc/h
Evaporator S3HC84E65	5900W/dT=10K, 2500 mc/h
Evaporator S3HC86E80	6300W/dT=10K, 2750 mc/h
Evaporator S3HC94E80	7950W/dT=10K, 5400 mc/h
Evaporator S3HC106E50	6700W/dT=10K, 2400 mc/h
Evaporator S3HC108E65	7100W/dT=10K, 2700 mc/h
Evaporator S3HC117E65	9200W/dT=10k, 5300 mc/h
Evaporator S3HC133E50	8000W/dT=10K, 2650 mc/h
Evaporator S3HC143E80	10650W/dT=10K, 5200 mc/h
Evaporator S3HC145E50	10800W/dT=10K, 5200 mc/h
Evaporator S3HC174E65	11950W/dT=10K, 5000 mc/h
Evaporator S3HC179E80	14150W/dT=10K, 7950 mc/h
Evaporator S3HC213E80	16000W/dT=10K, 7800 mc/h
Evaporator S3HC215E50	13500W/dT=10K, 4800 mc/h
Evaporator S3HC218E65	16100W/dT=10K, 7700 mc/h
Evaporator S3HC238E80	18800W/dT=10K, 10600 mc/h
Evaporator S3HC261E65	18000W/dT=10K, 7500 mc/h
Evaporator S3HC272E50	18400W/dT=10K, 7450 mc/h
Evaporator S3HC284E80	21300W/dT=10K, 10400 mc/h
Evaporator S3HC290E65	21500W/dT=10K, 10300 mc/h
Evaporator S3HC323E50	20200W/dT=10K, 7200 mc/h
Evaporator S3HC348E65	24000W/dT=10K, 10000 mc/h
Evaporator S3HC362E50	24800W/dT=10K, 9950 mc/h
Evaporator S3HC430E50	27200W/dT=10K, 9600 mc/h

